

ASSEMBLY INSTRUCTIONS

Comfort Series - Big & Tall

24 Hour Chair

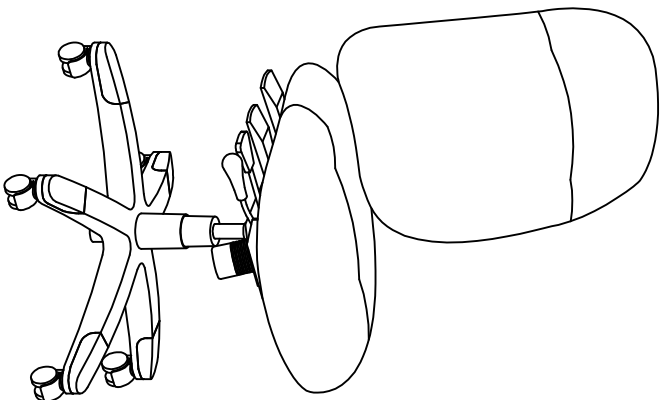







Model No. 2424AAGL

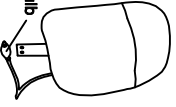

PARTS LIST 2424AAGL

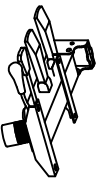
When ordering components, specific color and/or size information may be required.
Contact a Mayline Customer Service Representative. 1-800-822-8037

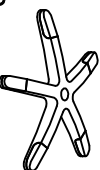
* Individual Items, Order by part number.
** Denotes Color Code.

Reference Letter A*	Quantity 1	Reference Letter F*	Quantity 1
102019 Lumber Bulb		Part Number 101520 Cylinder	
Part Number * 101598** Back		Reference Letter G*	Quantity 1
Reference Letter B*	Quantity 2	Part Number 101479 Cylinder Cover	
Part Number 101599** Seat		Reference Letter H*	Quantity 1
Reference Letter C	101447 Lumber Holster	Part Number 101433 Knob	
Part Number 101456 Mechanism		Part Number 101427* Hardware Bag	
Reference Letter D*	Quantity 1	Reference Letter J	Quantity 4
Part Number 101521 Castor (5 per pack)		Screw 5/16-18 X 1-1/4"	
Reference Letter E*	Quantity 1	Reference Letter K	Quantity 1
Part Number 101517 Base		Allen Wrench	
			Spare 1

Tiffany Industries™
A MAYLINE GROUP COMPANY

619 N. Commerce, P.O. Box 728
Sheboygan, WI 53082-0728

Toll Free: 1-800-822-8037
FAX: 920-457-7388
On Line: www.mayline.com

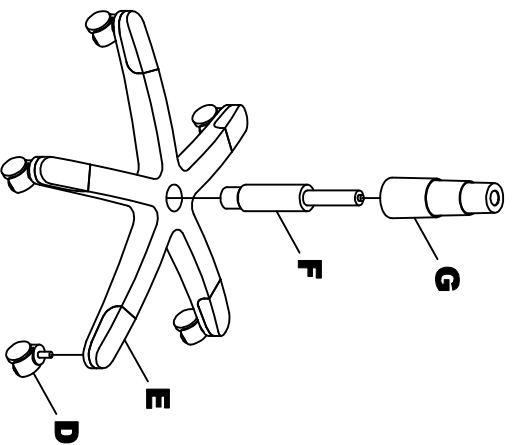

1. Place Base (E) upside down and push Casters (D) firmly into base. 5 places.
2. Turn Base right side up and insert Cylinder (F) into center hole of Base.
3. Place Cylinder Cover (G) over Cylinder.

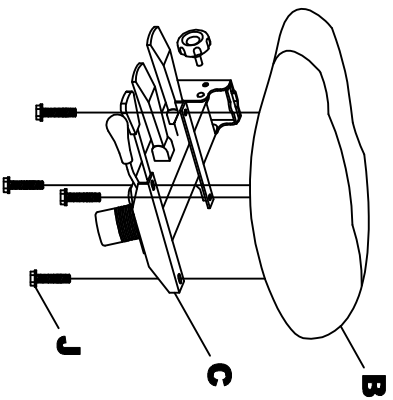

4. Assemble Mechanism (C) onto Seat (B) using Screws (J) 4 places.

2

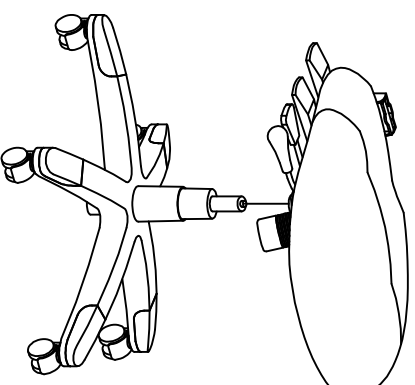

5. Carefully place seat assembly onto base assembly.

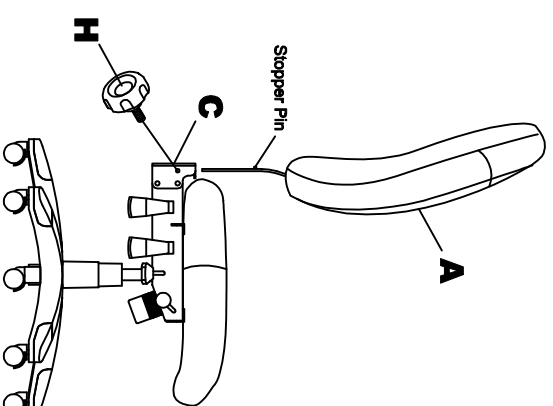

6. Insert Back (A) into Mechanism (C) until Stopper Pin hits mechanism.
7. Insert Knob (H) into Mechanism (C). Adjust Back to desired height and tighten Knob.

3

OPERATING INSTRUCTIONS FOR MULTI-FUNCTION MECHANISM

- 1. Back Height Control Knob.**
To raise the back, loosen knob and lift back upward, tighten knob.
- 2. Back Posture Adjustment**
To adjust angle of the back, pull paddle up. Adjust back, push knob down to lock.
- 3. Seat Posture Adjustment**
To adjust angle of the seat, pull paddle up. Adjust seat, push knob down to lock.
- 4. Seat Height Adjustment.**
To raise the seat, pull lever upward and raise your body up slightly to allow the chair to rise to the desired height.
To lower the seat, pull lever upward and apply weight downward on the seat.

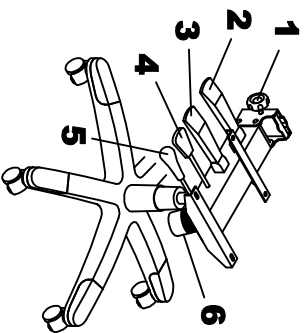

Note: To operate items 5 & 6, Item 3 must be unlocked (up position).

- 5. Seat Angle.**
To lock chair in upright position, lean forward and push knob toward chair.
To unlock chair in upright position, lean forward and pull away from chair.
- 6. Tilt Tension Control Knob.**
Turn knob clockwise to increase tilt tension.
Turn knob counter-clockwise to decrease tilt tension.

