

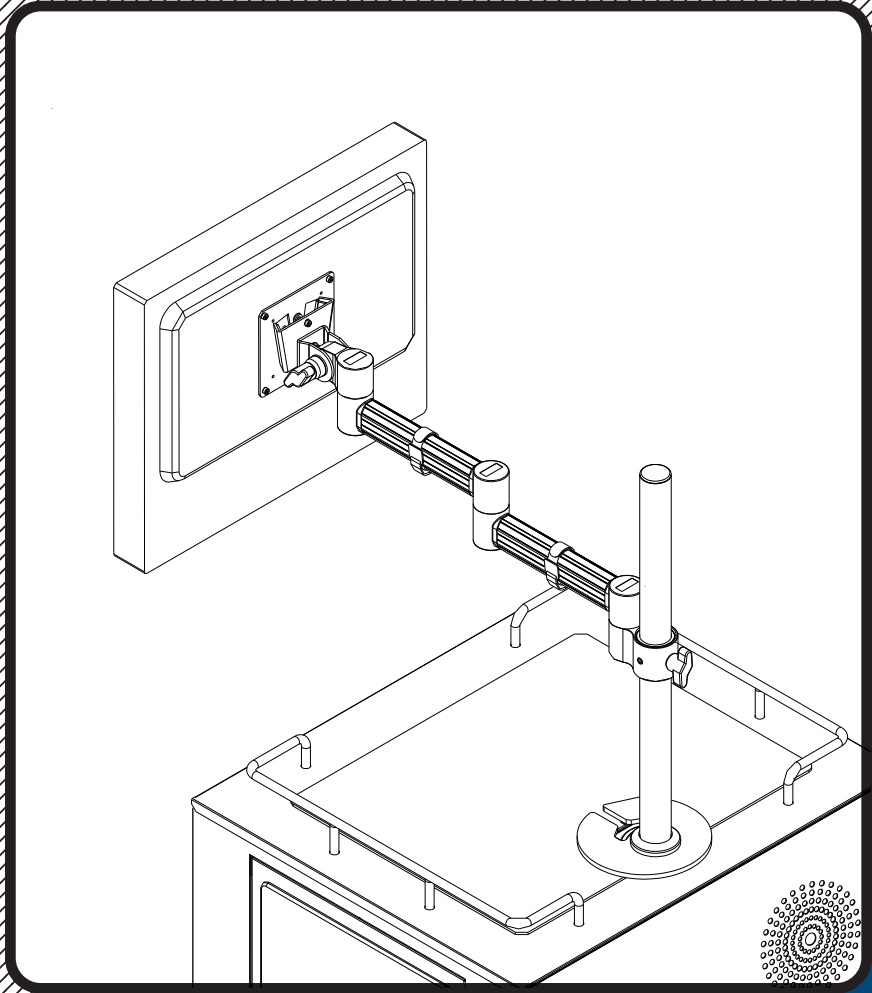







#66576 LCD Monitor Mount Boss Cart

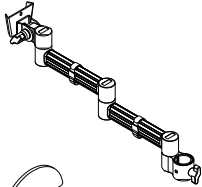
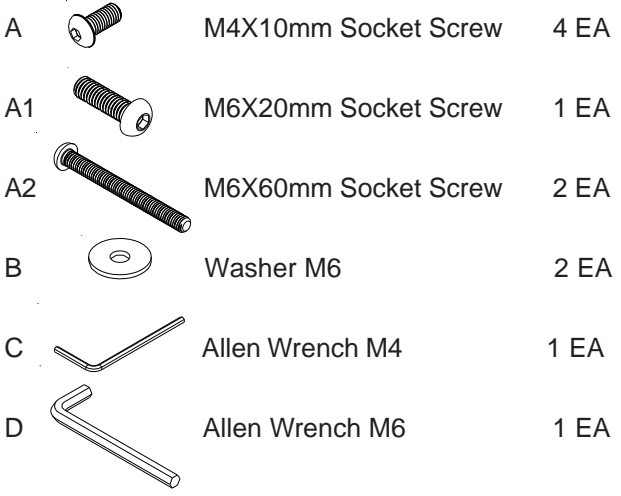
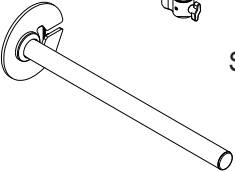
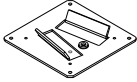

Assembly Instructions

#66576 Optional LCD Mount - Boss Cart

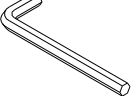

Part	Drawing	Description	Qty	Part	Drawing	Description	Qty
P-1		Moveable Arm	1 EA	Hardware List 			
P-2		Support Column	1 EA				
P-3		LCD Bracket	1 EA				
P-4		Base Plate	1 EA				
A		M4X10mm Socket Screw	4 EA				
A1		M6X20mm Socket Screw	1 EA				
A2		M6X60mm Socket Screw	2 EA				
B		Washer M6	2 EA				
C		Allen Wrench M4	1 EA				
D		Allen Wrench M6	1 EA				

READ THROUGH INSTRUCTIONS FROM BEGINNING TO END BEFORE STARTING TO ASSEMBLE UNIT.

1.) Identify and Separate all the Parts and Hardware.

Illustration # 1

Attach 1 LCD Bracket (P-3) to the back of LCD Monitor using 4 Screws (A) as shown in illustration # 1.

Tighten 4 screws using Allen Wrench (C).

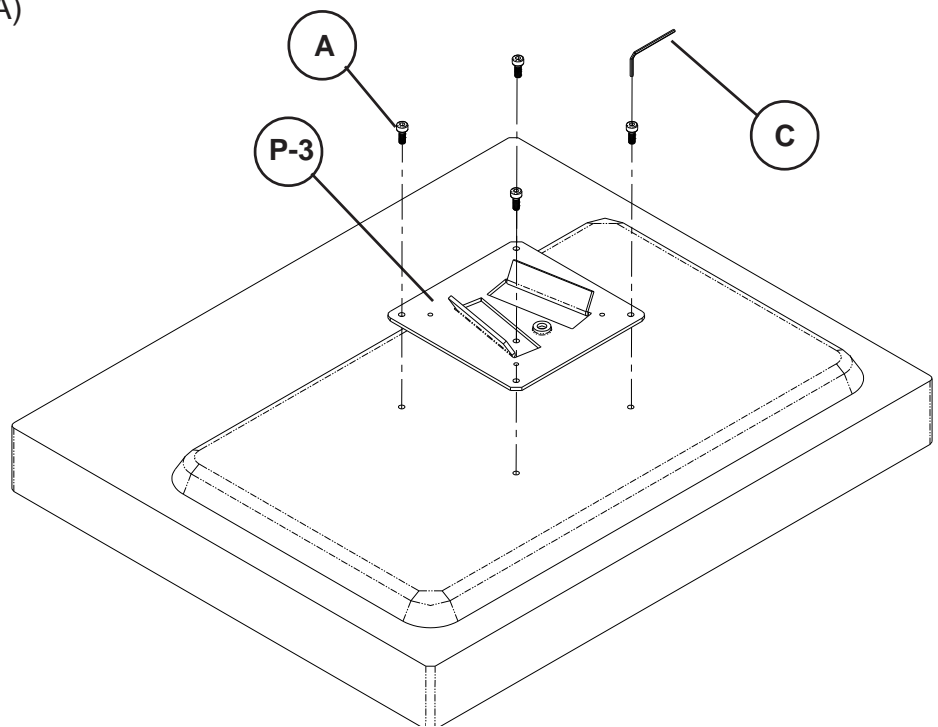

Do not use unless all screws are tight. At least every six months, check all screws to be sure they are tight. If parts are missing, broken, damaged, or worn, stop use of the product until repairs are made by your dealer using factory authorized parts.

#66576 Optional LCD Monitor Mount - Boss Cart

2.) Remove Plastic Grommet from the Top of Boss Cart.

Illustration # 2

3.) Place Support Column (P-2) over the Grommet hole in Boss Cart as shown in illustration #2. Align Base Plate (P-4) and secure using 2 Screws (A2) and 2 Washers (B). Tighten screws using Allen Wrench (D).

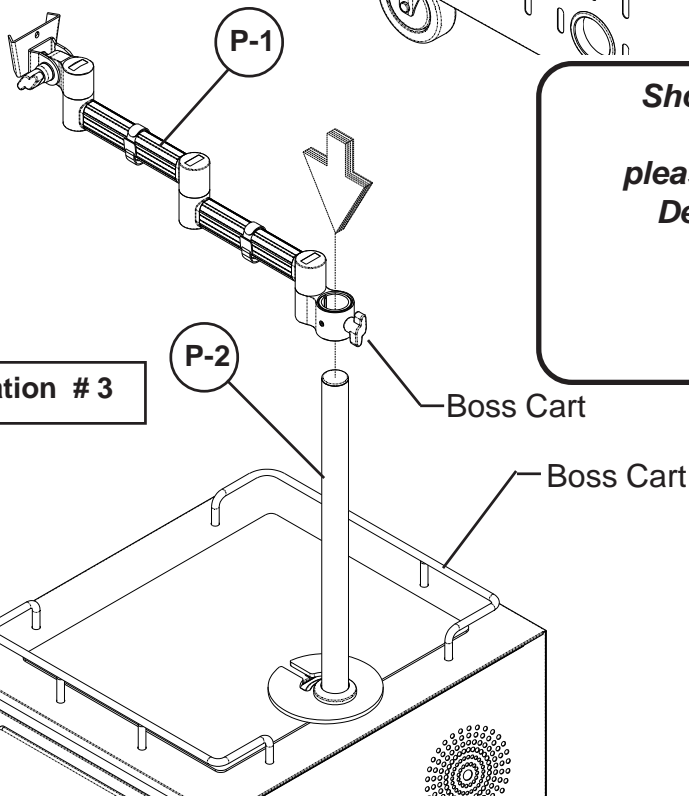
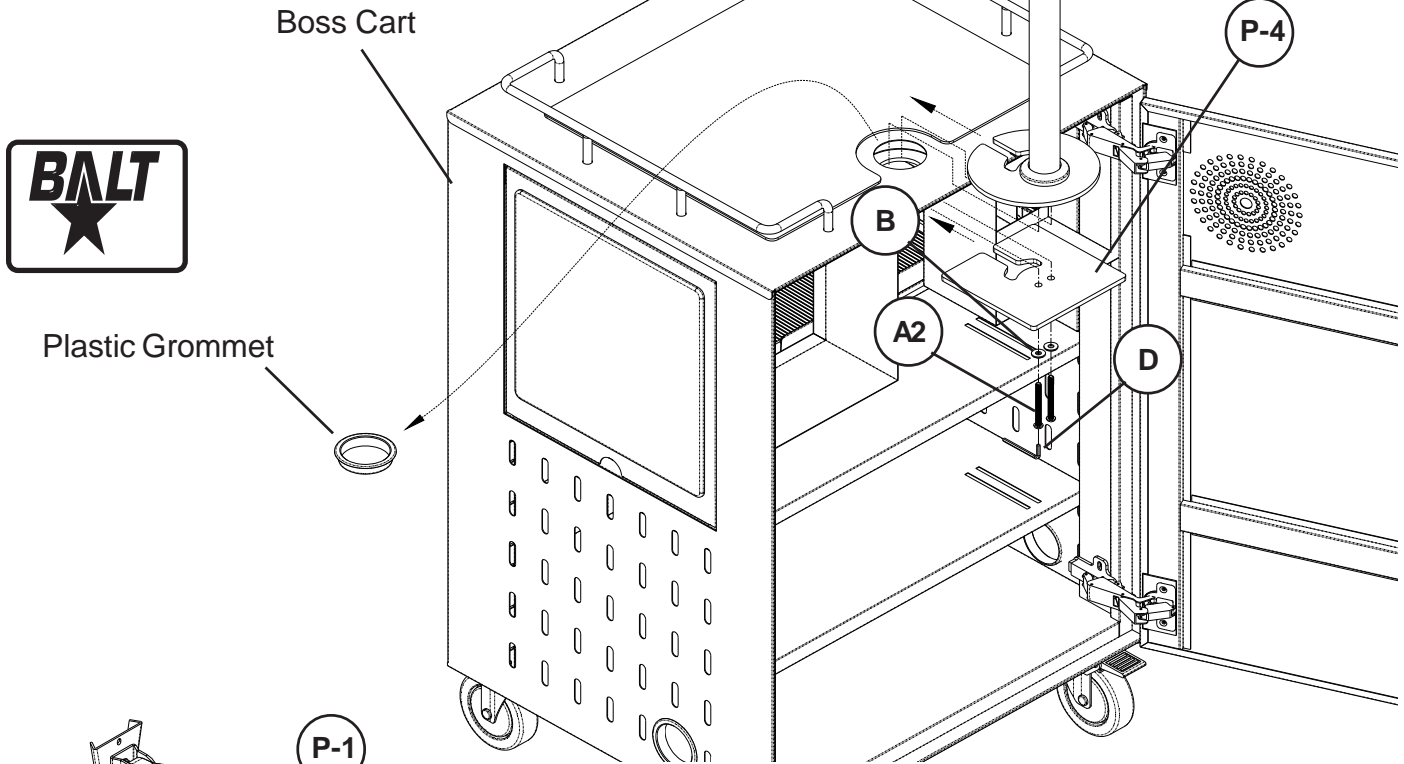

**Should you require assistance
during assembly,
please call our Customer Service
Department Monday - Friday
8 a.m. - 5 p.m.
Central Standard Time
1-800-749-2258**

4.) Slide Moveable Arm (P-1) over Support Column (P-2) as shown in illustration # 3.

5.) Secure Moveable Arm (P-1) at desired height by tightening Thumbscrew.

#66576 Optional LCD Mount for Boss Cart

6.) Slide LCD Bracket (P-3) onto Moveable Arm (P-1) and Secure using 1 Screw (A1) as shown in illustration # 4.

7.) Tighten screw using Allen Wrench (D).

Missing Parts or UPS Damaged Parts

For Your Convenience you can
EMAIL us at

[**furniture@baltinc.com**](mailto:furniture@baltinc.com)

24HOURS 7 DAYS A WEEK

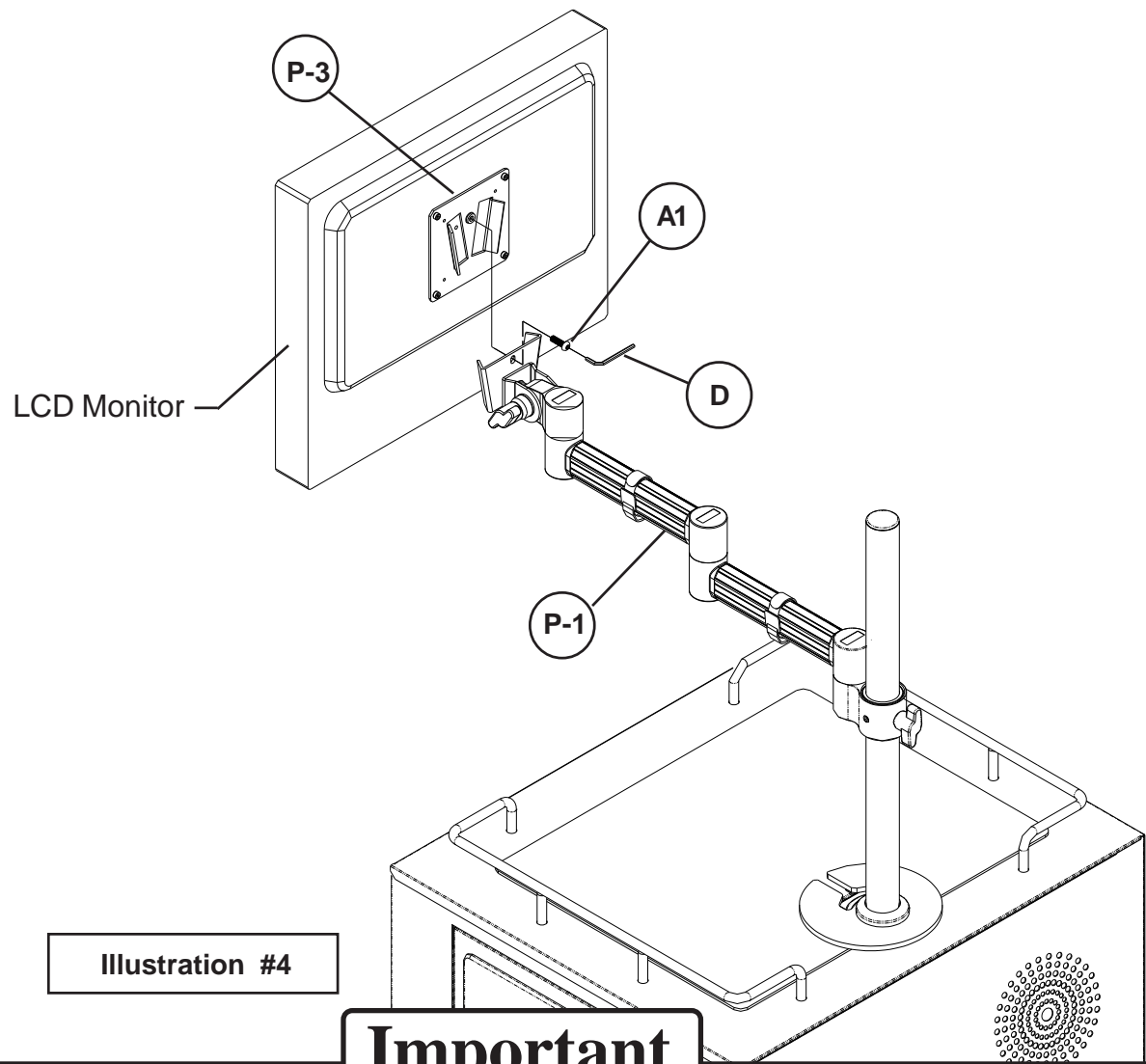

Illustration #4

Important

The Balt product you have purchased is guaranteed against material and workmanship defects. This guarantee extends 1 year from date of purchase. Should this product fail to function satisfactorily under normal use due to defect or imperfection, the defective part or product will be replaced. Damage caused by common carriers during shipment is not included in this guarantee.

This guarantee sets forth all applicable guarantees and remedies. No other warranty, expressed or implied shall apply. Failure to follow instructions found in Important Information Section of Owner Sheet shall void the guarantee. Consequential or incidental damages and or costs are not refundable.