

ASSEMBLY INSTRUCTIONS ACCORDE CONFERENCE TABLES

NOTE: Please count and inspect all pieces before disposing of any carton or packing materials.
All units consist of 2-3 cartons consisting of the following.

TOP CARTON When ordering components, specific color and/or size information may be required.
Contact a Mayline Customer Service Representative. 1-800-822-8037

| REF# | QTY. | DESCRIPTION | PART NO. | |
|------|------|-------------|------------|-------------------------------------------|
| 1 | 1 | Top | CALL ~-~** | ** Denotes Color Code ~-~ Denotes Size |

LEG ASSEMBLY CARTON (Qty. 2, 72"-108", Qty. 3, 120")

| REF# | QTY. | DESCRIPTION | PART NO. | |
|------|------|--------------|------------|-------------------------------------------|
| 2 | 1 | Leg Assembly | CALL ~-~** | * Individual Items, Order by part number. |
| 3 | 4 | Gusset | -- | |

HARDWARE BAG (Part No. 990043 Qty. 1 per Leg Assembly Carton) *

| REF# | QTY. | DESCRIPTION | PART NO. |
|------|------|-------------------|----------|
| E1 | 8 | Screw, M8 x 15/32 | -- |
| E2 | 14 | Screw, #10 x 3/4 | -- |
| E3 | 2 | Leveler | -- |

Tools Required for Assembly
Phillips Screw Driver

Note: A Magnetic or Power Driver may be used to assist in assembly.

- Place the Top (1) face down on a clean, flat surface. Attach Leg Assembly onto Top by aligning holes in the Leg Assembly with holes in the Top. See Fig #2
- Attach Leg Assembly using Screws (E2). See Fig. #2.
- Repeat Step 3 and 4 for each Leg Assembly.

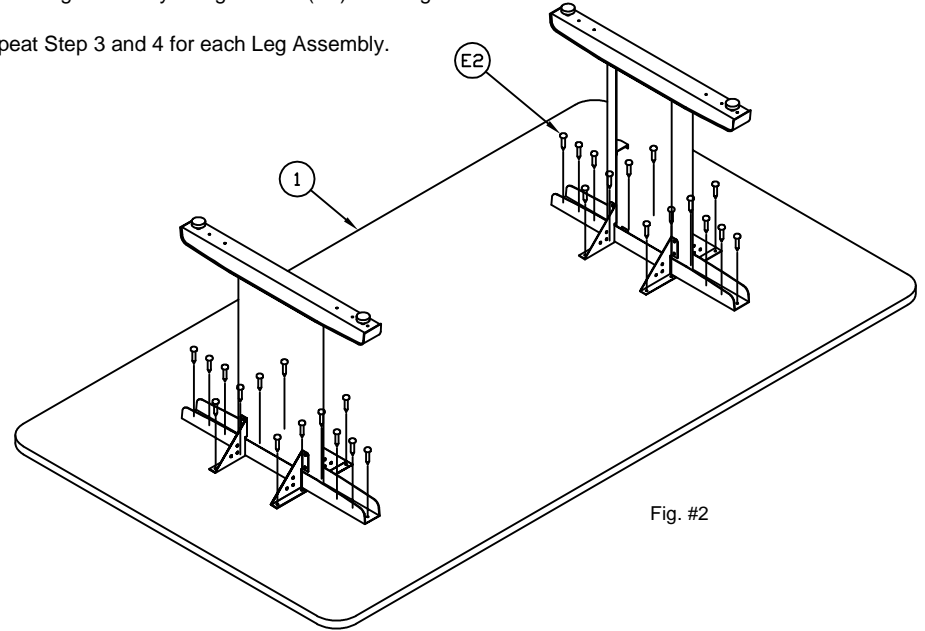

Fig. #2

- Begin assembly by attaching four Gussets (3) to Leg Assembly (2) using Screws (E1). See Fig. #1.
- Install two Levelers (E3) into Leg Assembly (2). See Fig. #1.

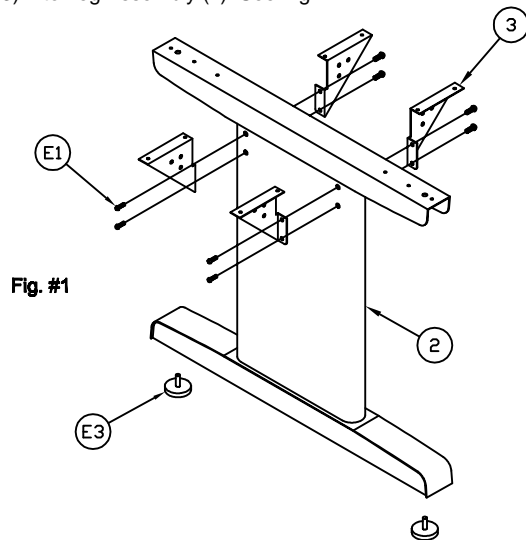

Fig. #1