

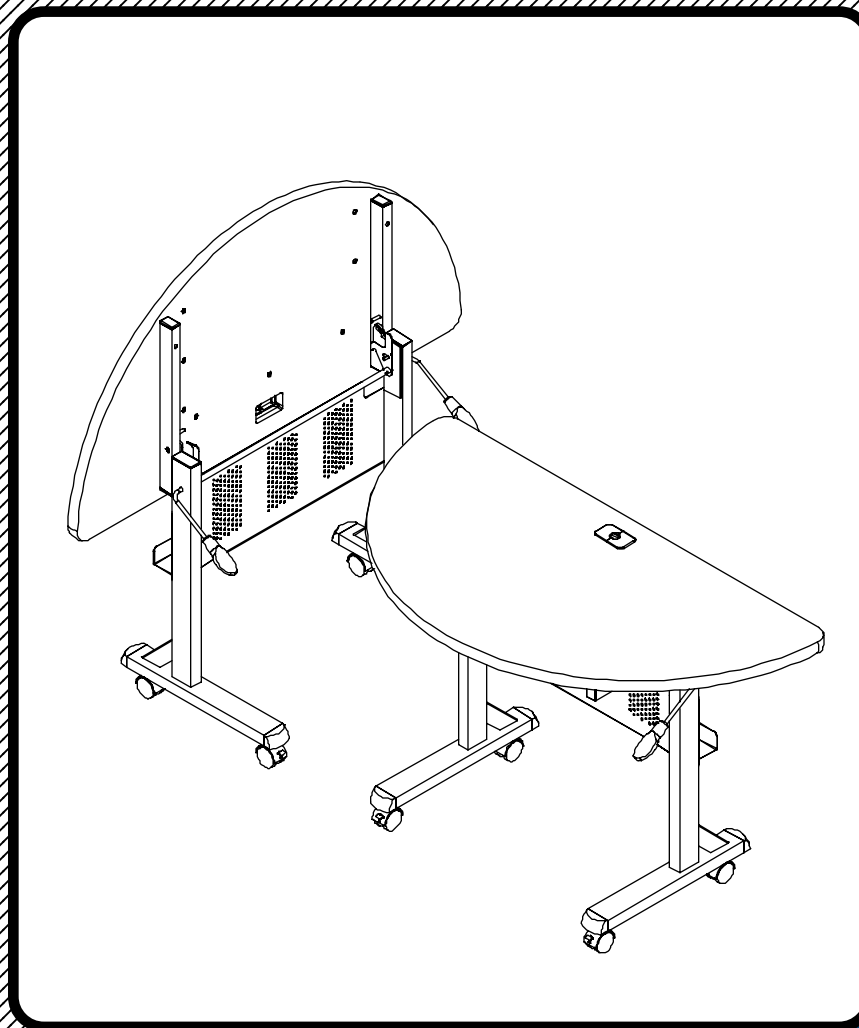

#89773

Flipper-48HR











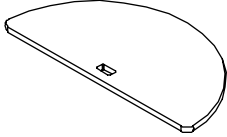

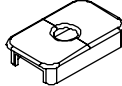





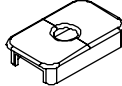

48" Half-round Conference Table

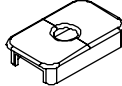

Assembly Instructions

Flipper-48HR

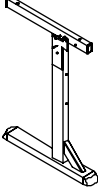
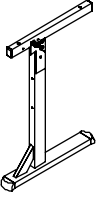
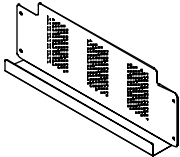
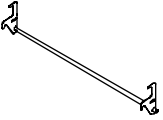
48" Half-round Conference Table

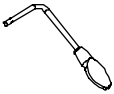
Part	Drawing	Description	Qty	Part	Drawing	Description	Qty																												
P1		Top Platform	1 EA	<div style="border: 2px solid black; border-radius: 15px; padding: 10px;"> <p style="text-align: center;">Hardware List</p> <table border="0"> <tr> <td>A</td> <td></td> <td>1/2" Socket Screw</td> <td>6 EA</td> </tr> <tr> <td>B</td> <td></td> <td>1-7/8" Socket Screw</td> <td>4 EA</td> </tr> <tr> <td>C</td> <td></td> <td>Plastic Grommet</td> <td>1 EA</td> </tr> <tr> <td>D</td> <td></td> <td>2" Locking Caster (front)</td> <td>2 EA</td> </tr> <tr> <td>E</td> <td></td> <td>2" Caster (Back)</td> <td>2 EA</td> </tr> <tr> <td>F</td> <td></td> <td>Allen Wrench</td> <td>1 EA</td> </tr> <tr> <td>G</td> <td></td> <td>Caster Wrench</td> <td>1 EA</td> </tr> </table> <p style="text-align: center;"><i>We recommend that you assemble this unit on a table.</i></p> </div>				A		1/2" Socket Screw	6 EA	B		1-7/8" Socket Screw	4 EA	C		Plastic Grommet	1 EA	D		2" Locking Caster (front)	2 EA	E		2" Caster (Back)	2 EA	F		Allen Wrench	1 EA	G		Caster Wrench	1 EA
A		1/2" Socket Screw	6 EA																																
B		1-7/8" Socket Screw	4 EA																																
C		Plastic Grommet	1 EA																																
D		2" Locking Caster (front)	2 EA																																
E		2" Caster (Back)	2 EA																																
F		Allen Wrench	1 EA																																
G		Caster Wrench	1 EA																																
P2		Left Leg	1 EA																																
P3		Right Leg (with Spring)	1 EA																																
P4		Metal Stability Panel	1 EA																																
P5		Welded Rod Assembly	1 EA																																
P6		Left Side Handle	1 EA																																
P7		Right Side Handle	1 EA																																

Missing Parts or UPS Damaged Parts

For Your Convenience you can
EMAIL us at
furniture@baltinc.com
24HOURS 7 DAYS A WEEK

***Should you require assistance during assembly,
please call our Customer Service Department
Monday - Friday 8 a.m. - 5 p.m.
Central Standard Time 1-800-749-2258***

Do not use unless all screws are tight. At least every six months, check all screws to be sure they are tight. If parts are missing, broken, damaged, or worn, stop use of the product until repairs are made by your dealer using factory authorized parts.

Flipper-48HR Assembly Diagram



READ THROUGH INSTRUCTIONS FROM BEGINNING TO END BEFORE STARTING TO ASSEMBLE UNIT.

- 1.) Identify and Separate all the Parts and Hardware.
- 2.) Slide the Right Side Handle (P7) Through the Right Leg (P-3) and into the Welded Rod (P5) as shown in illustration #1. Rotate Right Side Handle (P7) until holes are aligned (See illustration#1). Secure using 1 Screw (A).
- 3.) Slide the Left Side Handle (P6) Through the Left Leg (P-2) and into the Welded Rod (P5) as shown in illustration #1. Rotate Left Side Handle (P6) until holes are aligned (See illustration #1). Secure using 1 Screw (A).

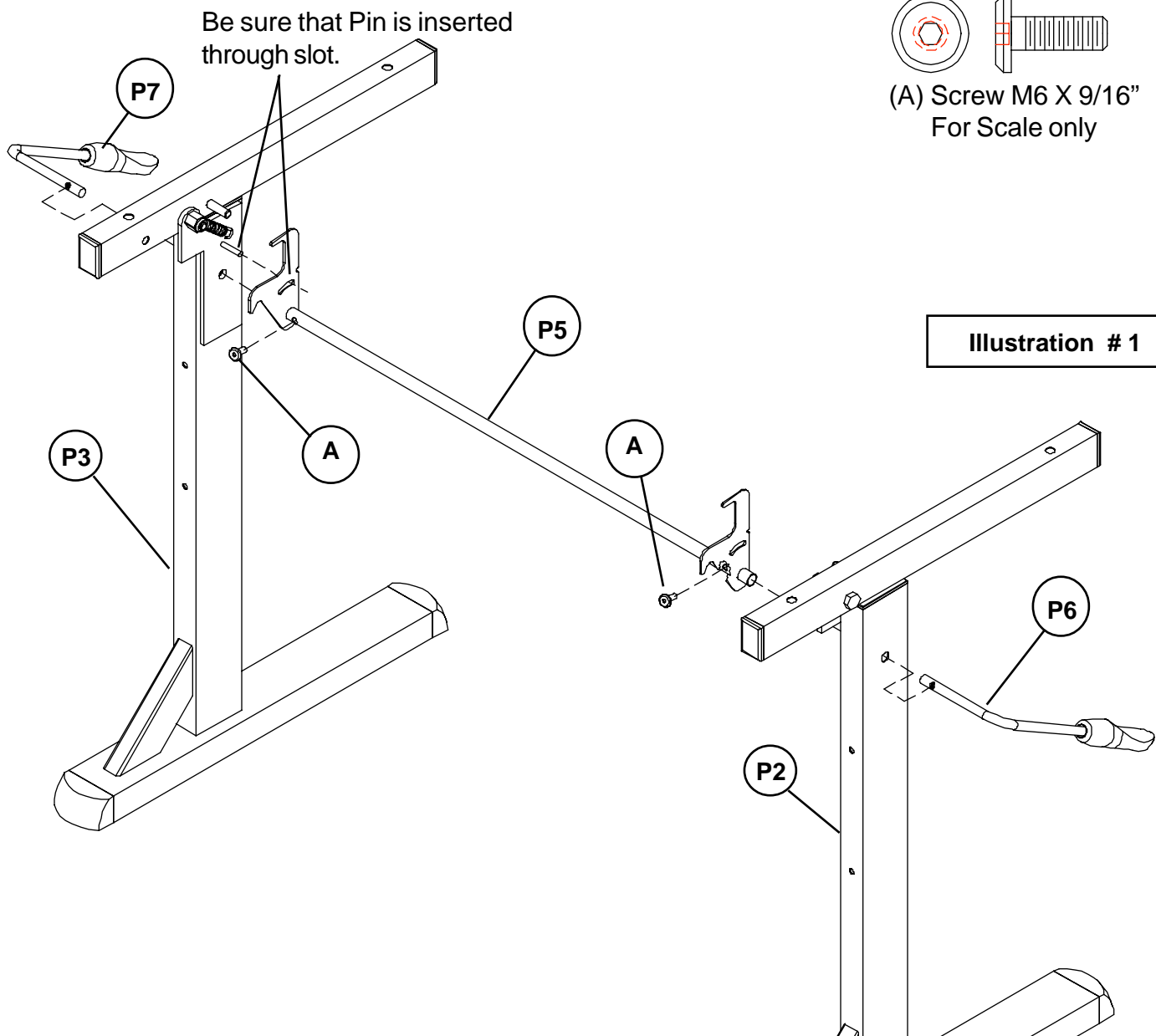
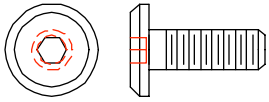
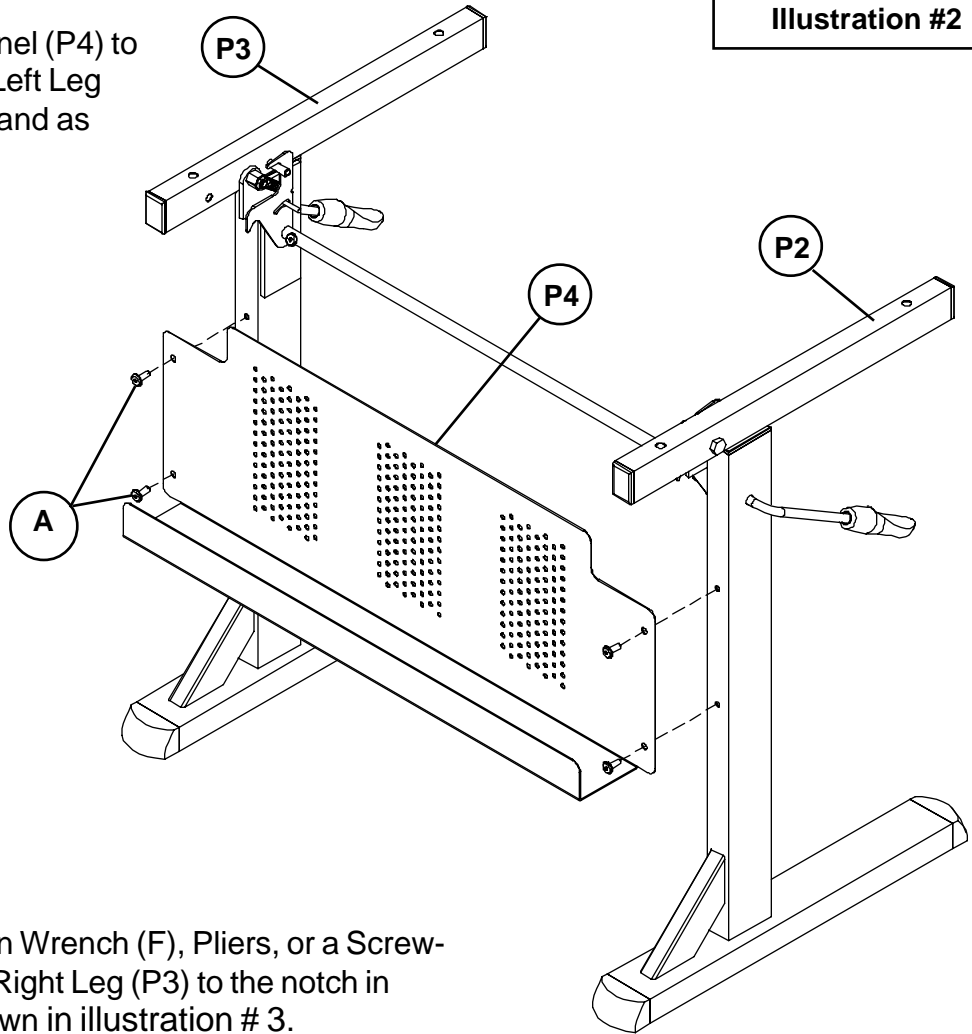

Illustration #2

4.) Attach Metal Stability Panel (P4) to the Right Leg (P-3) and Left Leg (P2) using 4 Screws (A) and as shown in illustration #2.



(A) Screw M6 X 9/16"
For Scale only



5.) Using the end of the Allen Wrench (F), Pliers, or a Screw-driver, Attach Spring on Right Leg (P3) to the notch in Welded Rod (P5) as shown in illustration # 3.

**Detail
Welded Rod (P5)**

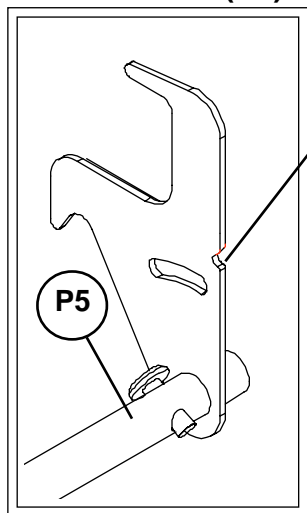

Notch

**Notch with
Spring Attached**

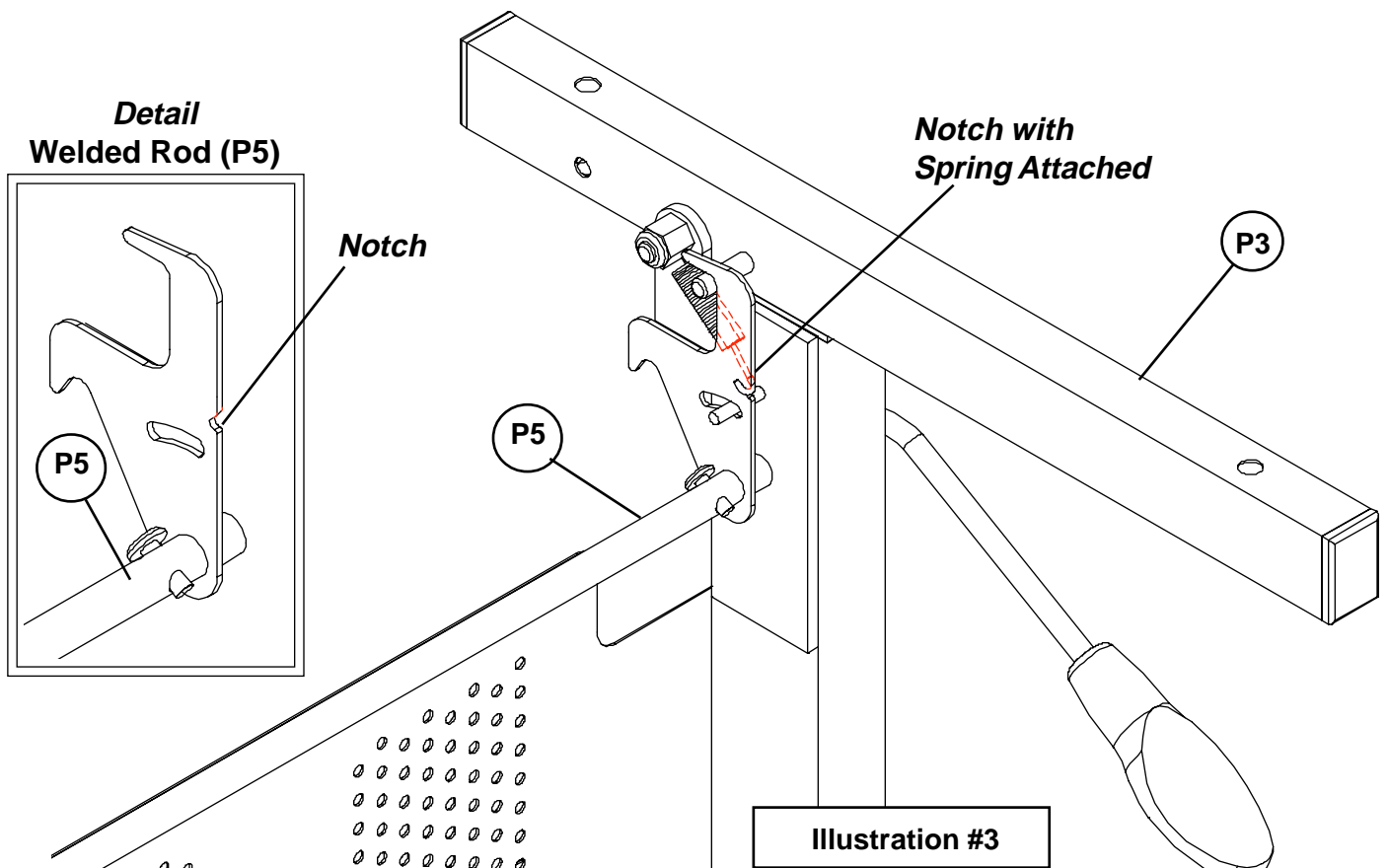
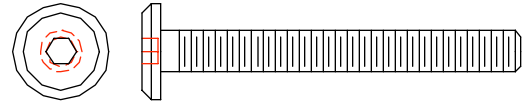

Illustration #3

6.) Place the Top Platform (P1) with the insert nuts facing up. Attach Right Leg (P-3) and Left Leg (P2) using 4 each (B) screws as shown in illustration #4.
(Finger tighten only)

7.) Attach 2 each (D) Locking Casters to the front of the Right Leg (P-3) and Left Leg (P2). Attach 2 each (E) Casters to the back of Right Leg (P-3) and Left Leg (P2). Tighten Casters using Caster Wrench (G).

(Tighten all screws using Allen Wrench (F).)



(B) Screw M6 X 1-3/8"
For Scale only

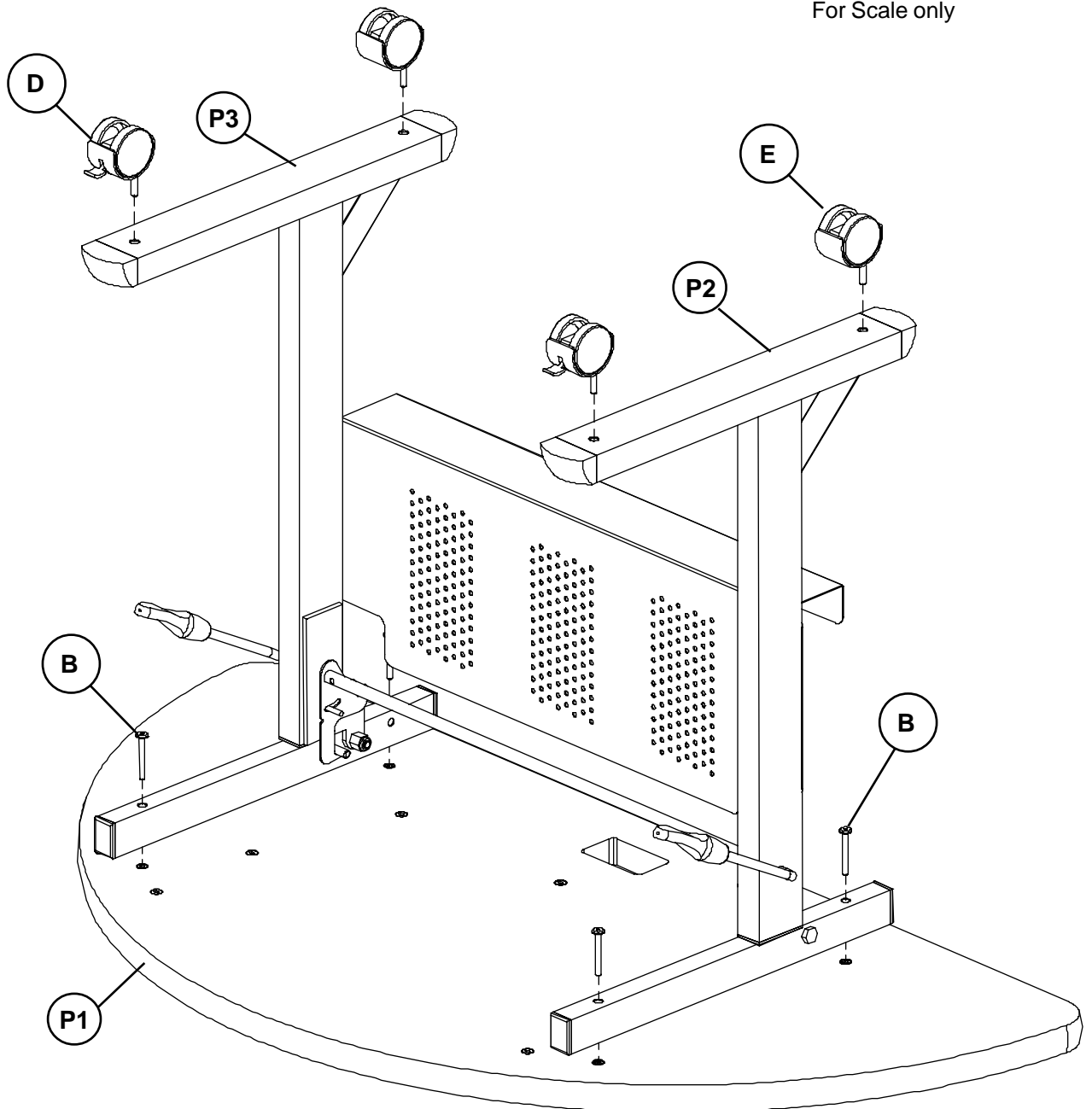
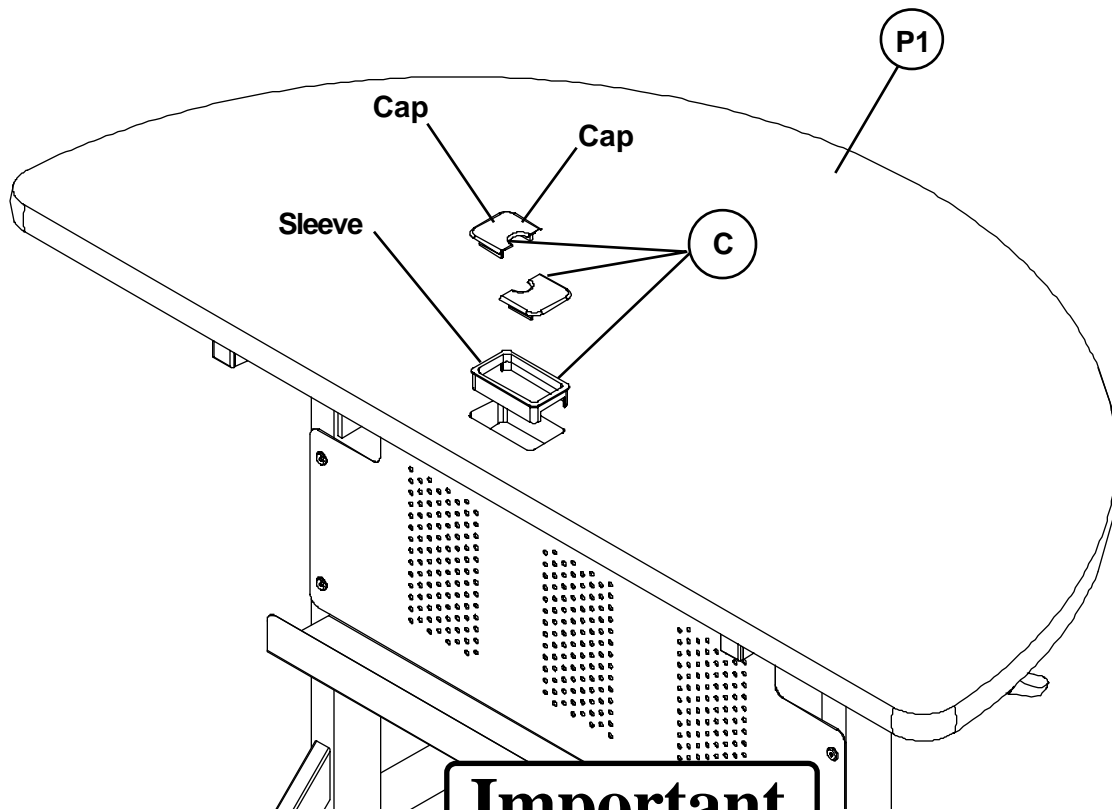
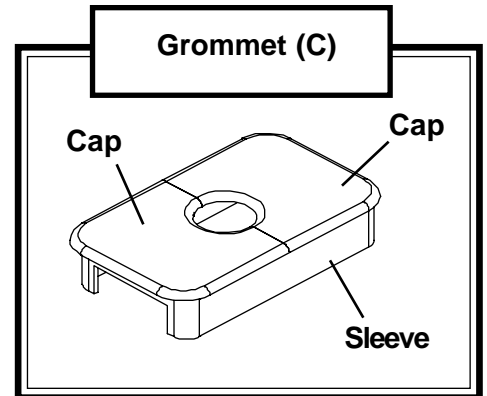

Illustration #4

8.) To install Grommet (C), separate parts and press Grommet Sleeve in rectangular openings in Top Platform (P1) as shown in illustration #5.

9.) Snap 2 plastic Caps over top of Sleeve as shown in illustration #5.

**Grommet(D) installation
Illustration #5**



Important

The Balt product you have purchased is guaranteed against material and workmanship defects. This guarantee extends 1 year from date of purchase. Should this product fail to function satisfactorily under normal use due to defect or imperfection, the defective part or product will be replaced. Damage caused by common carriers during shipment is not included in this guarantee.

This guarantee sets forth all applicable guarantees and remedies. No other warranty, expressed or implied shall apply. Failure to follow instructions found in Important Information Section of Owner Sheet shall void the guarantee. Consequential or incidental damages and or costs are not refundable.